

Installation instructions AZ186

Customized dowel-anchored plate with base, glueboard and placement hinge for type ALABTROS, in accordance with ETAG 005 guidelines for planning and execution of liquid- applied synthetic waterproofing for roofs, balconies and terraces). The method used here comprises an externally insulated roof system based on bonding a vapour barrier and sealing with roofing membranes (bitumen sheet insulation or synthetic waterproofing material).

The following instructions include all information necessary for the installation of this anchor plate. To avoid any misunderstanding we advise you to read these instructions carefully and then keep them for later reference.



Caution

Non- observation of operating instructions can result in personal injuries or damage to property.

Please note that if these instructions are not observed, the manufacturer cannot assume any liability or guarantee.

- Always follow the safety regulations.
- Should you not understand any part of these operating instructions, please contact your MAY dealer.

Diagram showing installation materials and tools

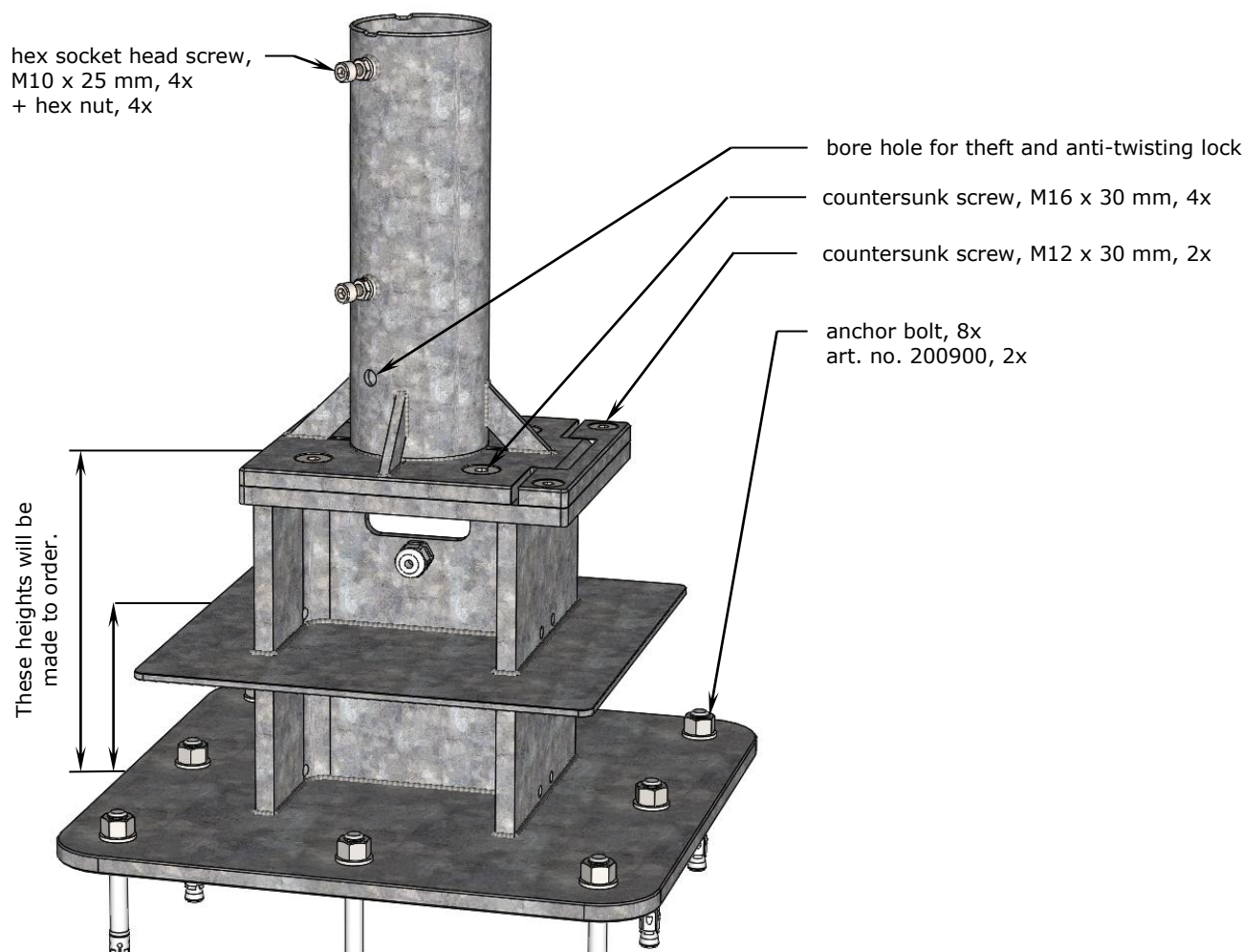

Flat-roof structure: single-layer, unvented

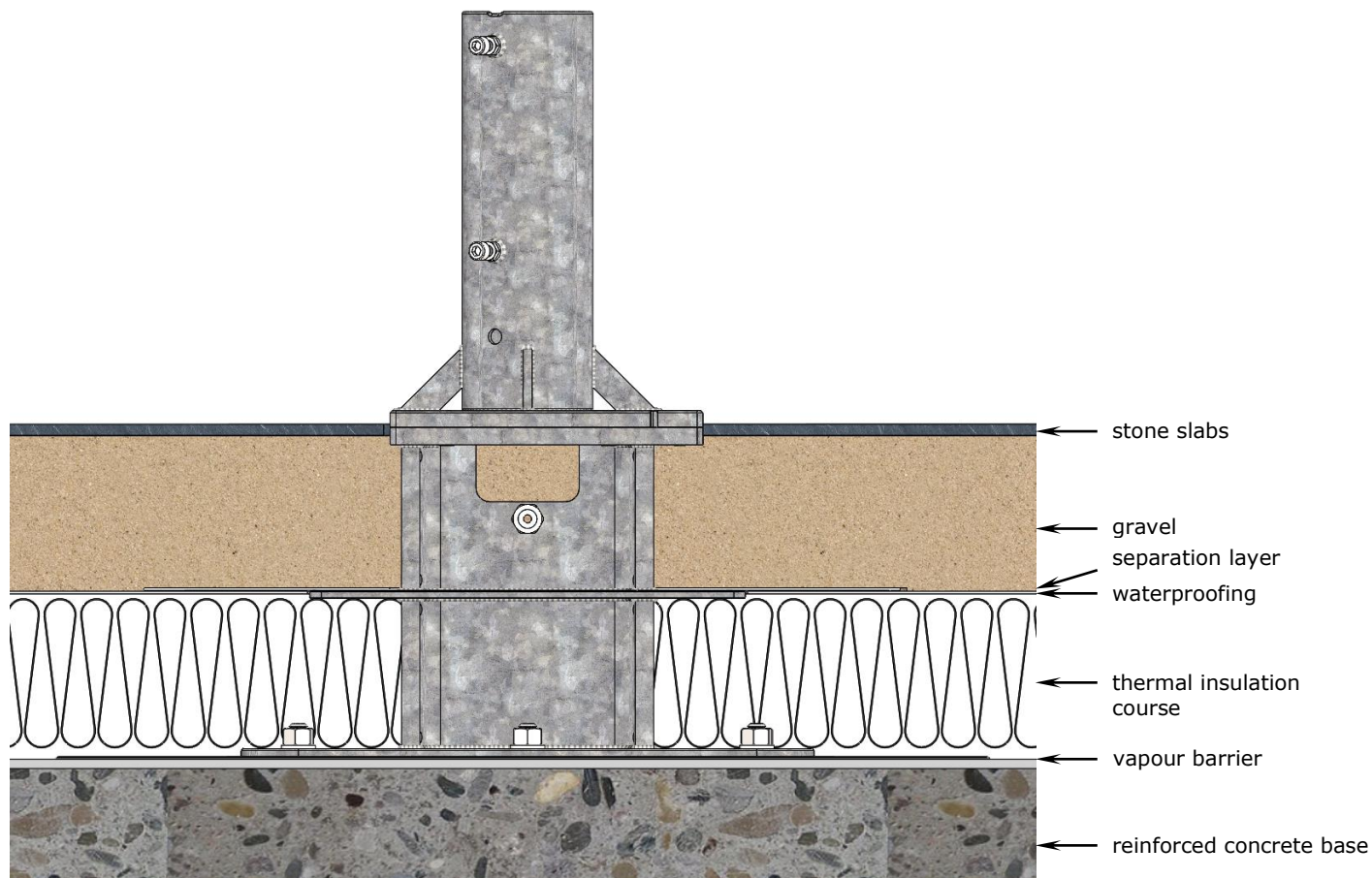

Positioning AZ186 and preparation of the vapour barrier

Start from the following initial state of the roof terrace: the bitumen sheets have not yet been placed, i.e. the reinforced concrete base is in substrate condition.



Caution

This flat-roof installation should be carried out solely by a qualified roofing contractor. Non-observance may result in property damage.

Please note that the applicable regulations for roof waterproofing and the most recent DIN norms valid for the entire craft must be observed. The manufacturer has included some additional technical hints to aid correct installation. Nevertheless, MAY cannot assume any liability or guarantee for incorrect installation.

1. Place a purpose-made vapour barrier membrane (1 x 1 m) in the middle of the designated position for the ALBATROS parasol main axis. Ideally, the vapour barrier would be made of Wolfin GW SK bitumen- compatible synthetic membrane. This is produced on the base of PVC-P-BV in accordance with DIN 16937 and 16730. Technical data: thickness 2.3 mm, underside glass fiber mesh reinforcement, coated with a cold-bonding self- adhesive layer.

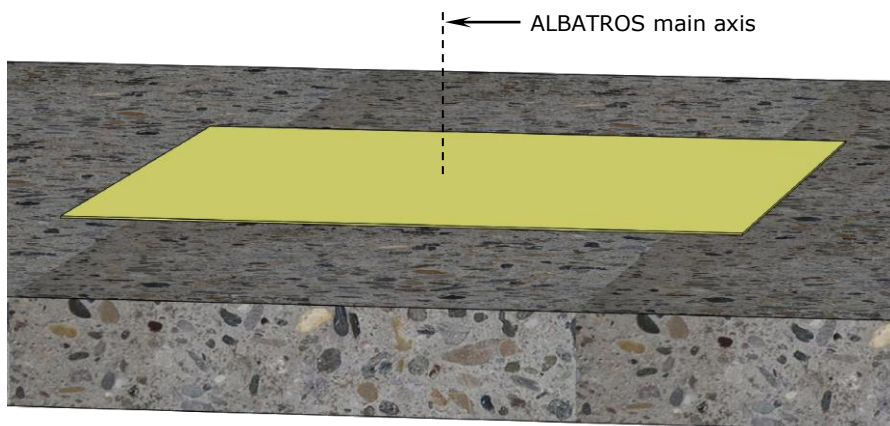

2. Screw the upper foot onto the lower part (cf. illustration). Use the M16 countersunk screws and the M12 mm countersunk screws and tighten them. Tighten all screws using the 10 mm and 8 mm hex keys provided.

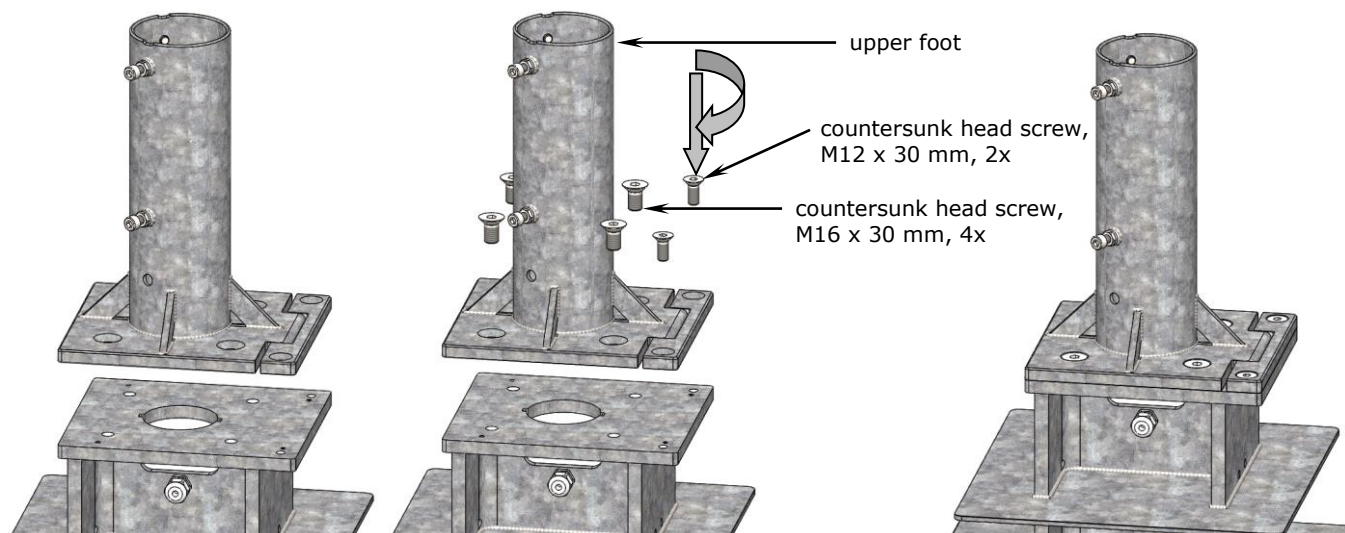



Caution

Screws that are not tightened correctly will work loose.

If screws are not tightened firmly enough, there will not be sufficient tensile force to trigger self-locking. If the screws are tightened too firmly and over-stressed, the screw connection may slacken.

- Tighten the M16 screw manually using the enclosed hex key and extension. Exert as much force as possible. With the enclosed tools there is virtually no risk of over-stressing.
- The correct torque for a torque wrench for M16 is 150 Nm, for M12 it is 70 Nm.



Caution

The thread can get damaged.

As sand is harder than steel, the thread may get damaged if a sand-covered screw is turned.

- Clean and grease screw and thread hole.
-

3. Choose the location for your AZ186. Put the placement hinge in a position that will allow enough space for the parasol to be erected and dismantled.

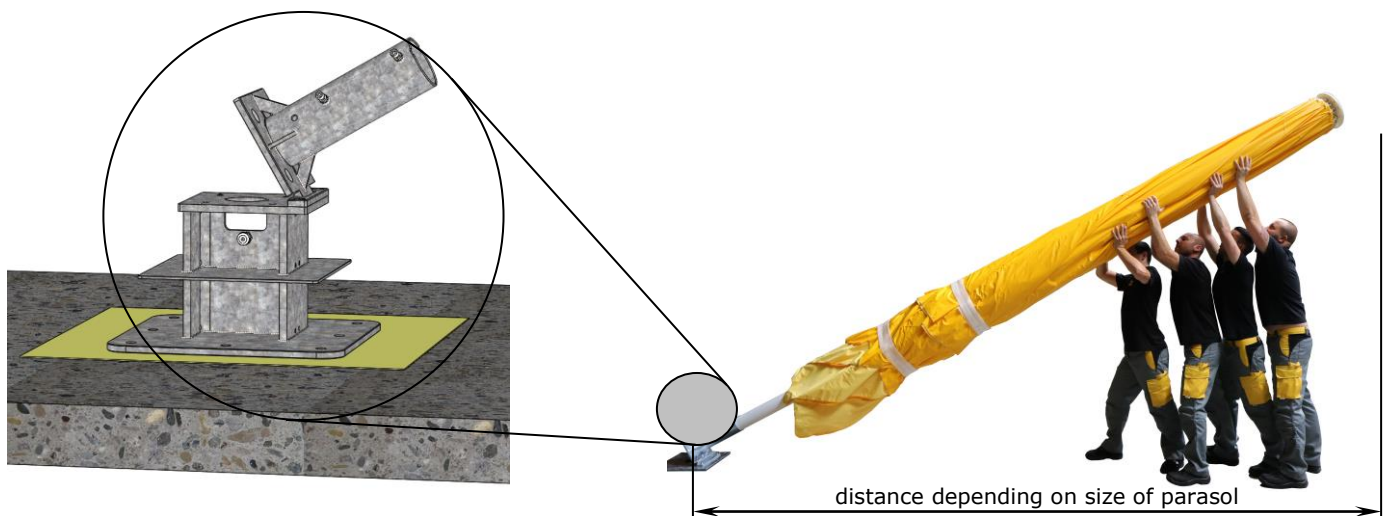

4. When positioning the AZ186, be sure to measure exactly where the parasol axis should be. Allow sufficient space between parasols or between the wall of the building and the parasol.



Caution

Parasols that are located too close together wear sooner.

Parasols may sway slightly. If there is not enough space between them, they may touch and abrade or scrape the canopy fabric at the spoke ends.

- Make sure that there is a clearance of approx. 30 cm between the parasols (or between parasol and the wall of the building).
-

5. Note that uneven patios are no problem. We are able to compensate any unevenness of the ground by adjusting the height of each individual parasol. Extra-length upper foots are available at 10 cm gradation. These can be adjusted in height on location with the help of inside spacers. Instructions: may.ag/extralength.pdf

6. Align the AZ186 into vertical position.



Caution

Screws that are not tightened correctly will work loose.

If screws are not tightened firmly enough, there will not be sufficient tensile force to trigger self-locking. If the screws are tightened too firmly and over-stressed, the screw connection may slacken.

- Tighten the M16 screws manually using the enclosed hex key and extension. Exert as much force as possible. With the enclosed tools there is virtually no risk of over-stressing.
- The correct torque for a torque spanner for M16 is 150 Nm, for M12 screw 70 Nm.



Caution

The thread can get damaged.

As sand is harder than steel, the thread may get damaged if a sand-covered screw is turned.

- Clean and grease screw and thread hole.



Attention

If the parasol is to be in a vertical position, the anchor plate must be embedded in the concrete absolutely horizontally.

If the upper component of AZ186 is not in an absolutely vertical position, the parasol will stand slanted. This would have a negative impact on the overall optical appearance of the parasol. Especially when there are several parasols in a row, even an inexperienced passer-by would notice that they are not straight.

- Use a spirit level to align the AZ186 (cf. illustration).
 - Use wedges or, if necessary, washers under the corners. The wedges should be as broad as possible so that the load is well distributed and will not damage the vapour barrier membrane.
-

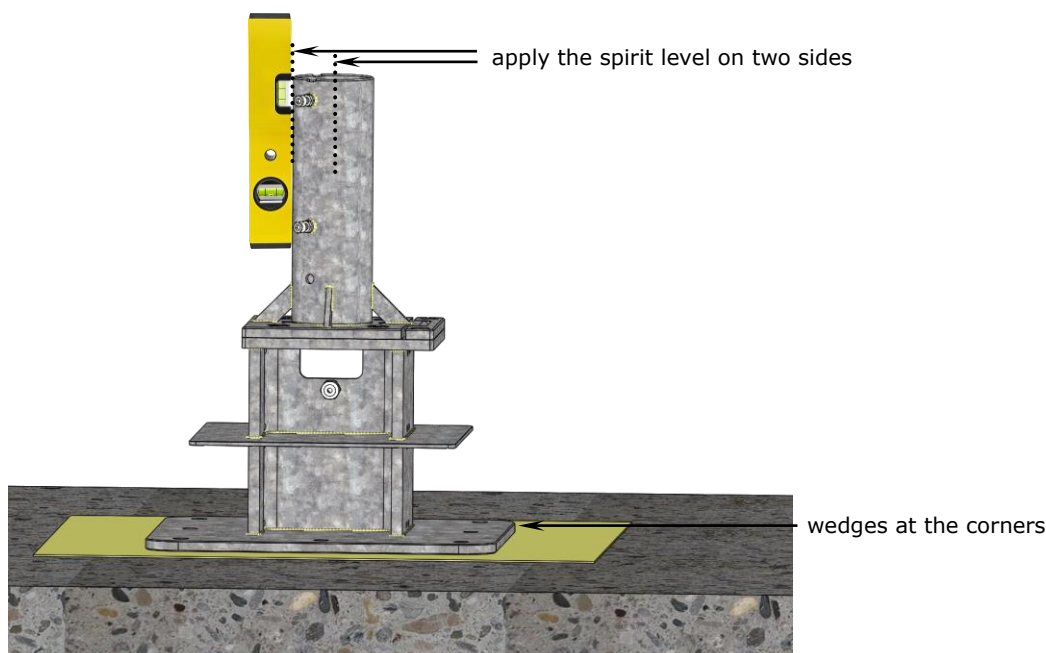

7. When setting the AZ186, make sure that the base plate of the bottom component is flush with the terrace floor surface.



Caution

Avoid tripping hazard.

To ensure that the cover plate (needed as a protective cover in winter when the upper anchor foot has been removed) is flush, the bottom component must be set 4 mm below the terrace surface (cf. illustration). This difference of 4 mm corresponds to the space needed for the 4 mm-thick checker plate for winter protection.

- When ordering, make sure that you state the correct height measurements required for the bottom component so that the distance between the top of the reinforced concrete base and the top edge of the terrace surface can be bridged properly. Please use our special MAY order form for custom-made production.
- In case of doubt, state a measurement that is slightly too short. The missing height can then be jacked up. Measurements that are too long cannot be adjusted.
- To reach the correct height of the lower component, push wedges under all four corners. The wedges should be as broad as possible so that the load is well distributed and will not damage the vapour barrier membrane. Ideally, the wedges should only be used to jack up the plate. The hollow space beneath the base plate should then be stuffed with epoxy resin sealing mortar until the plate is completely stable and safe.

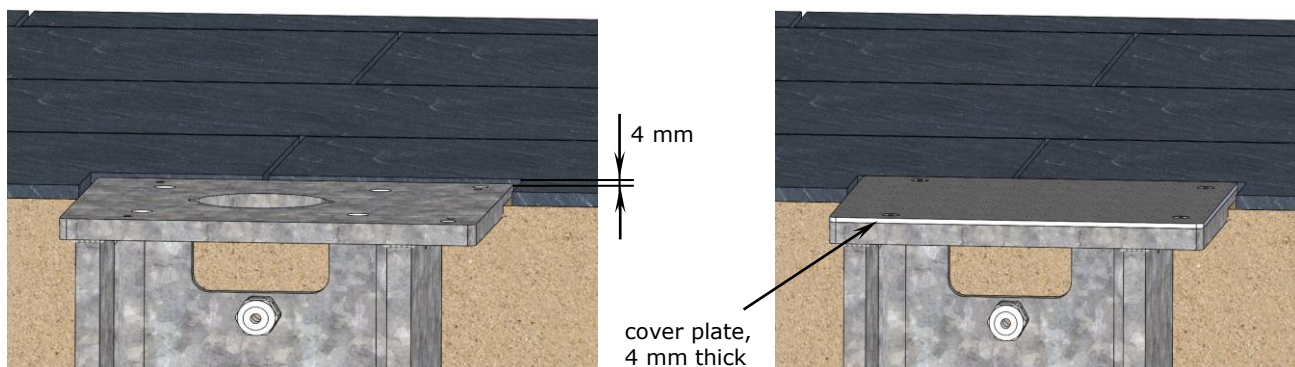

8.



Caution

Functioning of the placement hinge.

If your AZ186 has not been installed in the correct height, do at least make sure that the bottom component has not been set too far down. If there is too great a height difference, the placement hinge will not tilt into horizontal position and the parasol cannot be erected properly. Moreover, the electrician will have difficulties running the cables.

- Match the height of the gravel bed to that of the stone slabs.
- If there is a height difference of over 50 mm, functioning of the placement hinge will be seriously restricted.

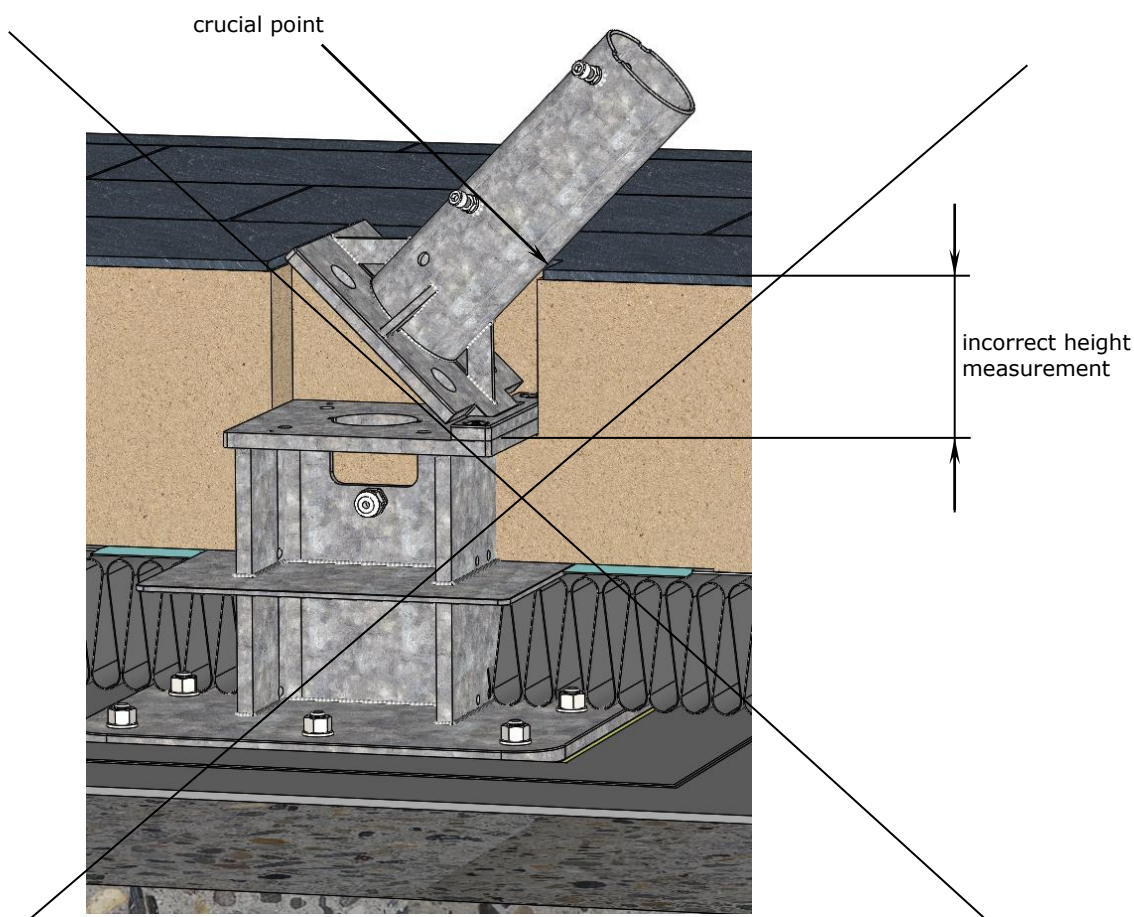

Fixing the anchor plate

1. Use a hammer drill to drive the 8 bore holes for dowels into the reinforced concrete surface. The drill pattern for the anchor plate is as shown below:

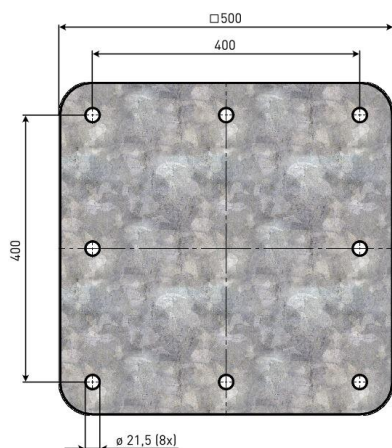

2. Screw the anchor plate onto the reinforced concrete surface. If you use anchor bolts provided by other manufacturers, please observe their instructions. Anchor bolts supplied by MAY should be mounted as follows:

Art. no. 200900, 2 packages necessary, threaded bolt with nut, stainless steel A4:

- a. Using a 16 mm hammer drill, drill a min. 110 mm-deep hole into the concrete.

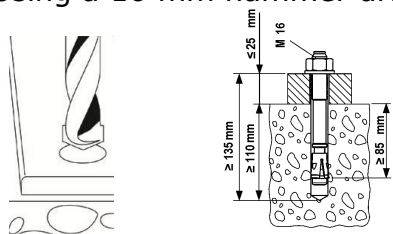

- b. Clean the bore hole with compressed air.



- c. Drive the anchor bolt into the hole. Before doing so, be sure to position the hex nut correctly. (The drive-in pin of the threaded bolt should jut out of the hex nut approx. 2 - 3 mm.)

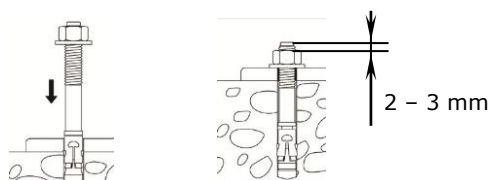

d. Use a torque wrench to tighten the nut with 110 Nm.

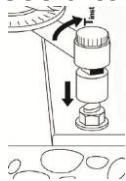

Danger

A falling parasol can cause serious or even fatal injury.

If the dimensions of the anchor bolts do not match the size of the parasol, the parasol may fall and cause injuries.

- Always determine the appropriate bolt size with the help of a specialist.
- Anchor bolts of MAY company are approved for cracked and non-cracked concrete B25 till B55 and C20/25 to C50/60. Also suitable for concrete C12/15 and natural stone with dense structure.

Bonding vapour barrier membranes

1. Under the anchor plate there is a vapour barrier membrane with a 25 cm connecting face. Use this to bond vapour barrier membranes made of bitumen sheeting or similar materials.

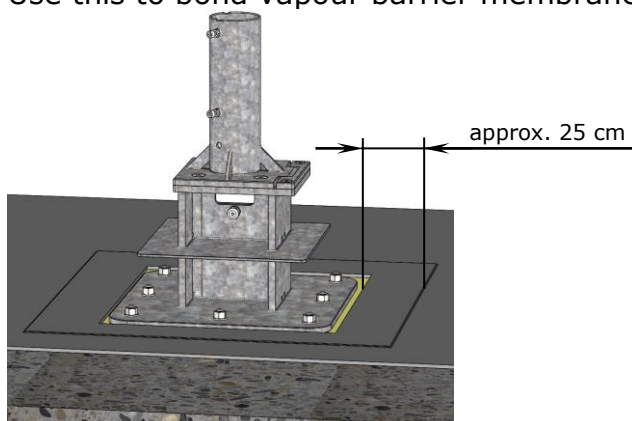

- Fill up the thermal insulation course with insulating material as far as the bottom of the adhesive flange plate.

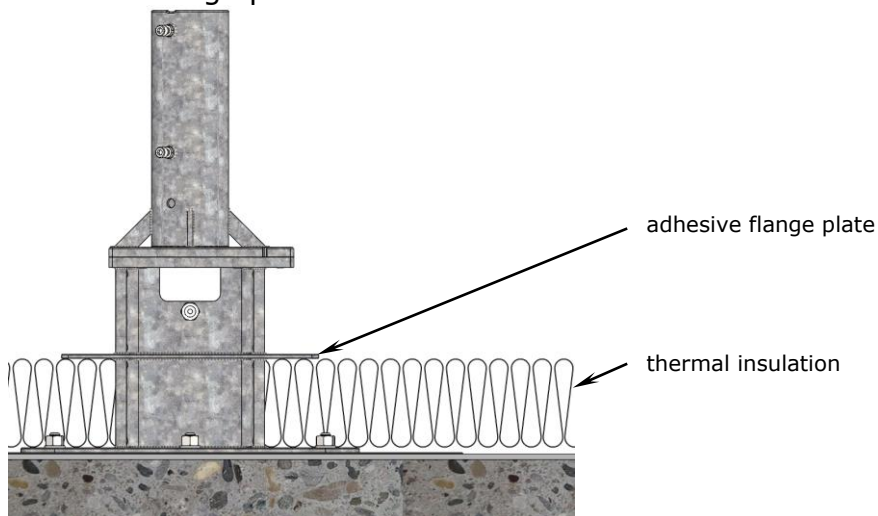

- Spread out the waterproofing sealing membrane on the insulation layer. When doing so, cut out a hole in the membrane so that it will fit exactly round the adhesive flange and thus form a butt joint. Depending on the waterproofing membrane used, it may be necessary to reinforce with further layers.

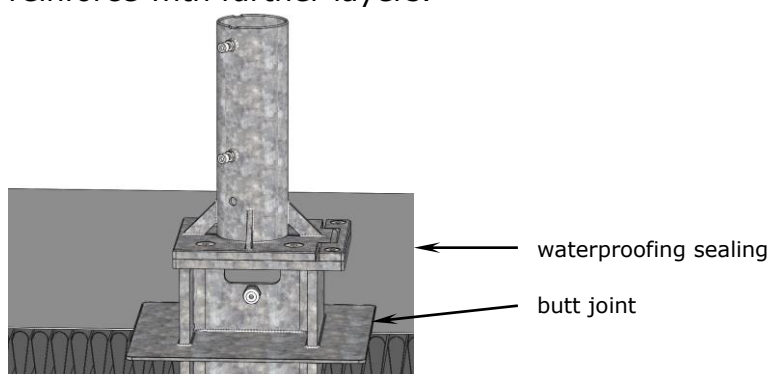

- The surface of the flange plate that is to be covered with liquid waterproofing resin must be rubbed down and cleaned thoroughly, if necessary with a special cleaning agent. In addition, this surface must be primed in accordance with the producer's priming chart for liquid synthetic resins. The fleece can now be bonded properly. The next step is to spread the liquid waterproofing resin right round the adhesive flange with a width of somewhat over 10 cm.

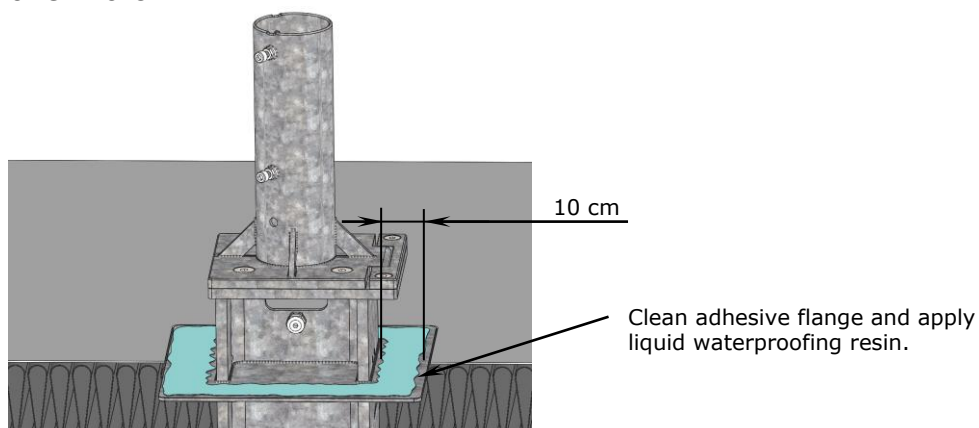

- Now apply about a width of 10 cm of the liquid waterproofing resin right round the adjoining surface of the waterproofing sealing membrane. So you now have a fleece seal of at least 20 cm width.



Caution

The seal must be completely water-proof, otherwise water may damage the terrace.

The person or company in charge of carrying out the waterproofing work is responsible for ensuring that the liquid waterproofing resin is compatible with the sealing membrane to be used. As a rule, producers supply an application chart for the different sealing membranes.

- If in doubt, the mixture of substance compounds should be performed on site or in the laboratory of the product manufacturer.
- The waterproofing process must be carried out in accordance with the bonding instructions of the producer of liquid -applied synthetic waterproofing materials. The MAY company cannot assume liability or warranty for non-observance.

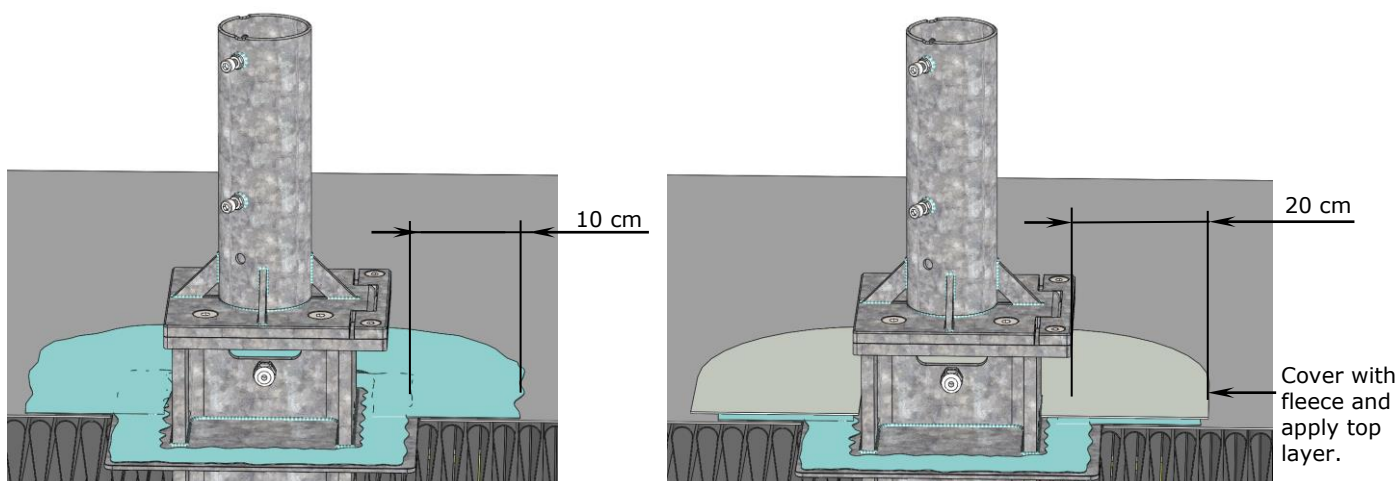

Power supply (optional)

- Press the flexible connecting rubber lead (certified approval for outdoor use necessary) through the cable gland and tighten the nut so that the rubber is narrowed and tension relief is provided.

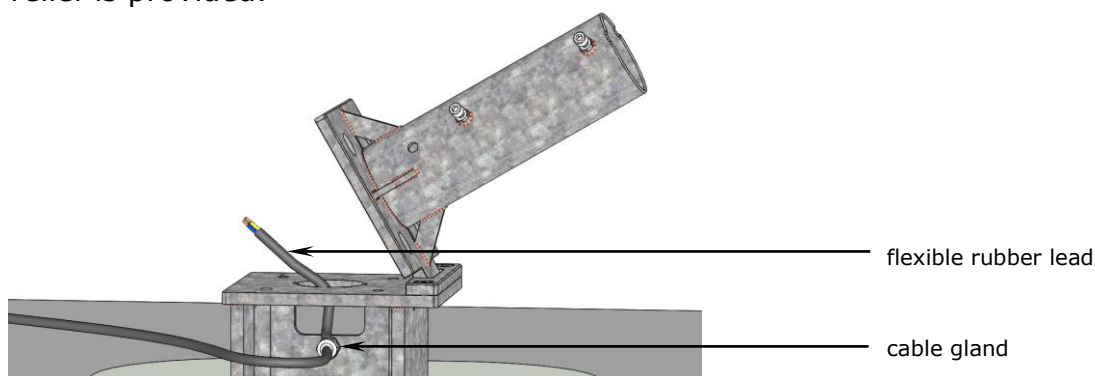

2. Connect the flexible rubber lead (certified approval for outdoor use necessary) and the parasol power-supply. The connection must be absolutely watertight. The ground cable should be installed by a qualified electrician and should be appropriate for the designated consumers and length of the lead.

- power supply for heaters: 5-pole, min. 4 mm² cable cross section
- power supply for light: 230 V, 3-pole, min. 1.5 mm² cable cross section; or for 12 V, lay out individually



Danger

Electric installation work must be carried out solely by a certified electrician. Disregarding this warning may result in serious personal injuries.



Danger

To avoid personal injury in case of faults.

Water in the plug connector can lead to a short circuit. Protect the connector against any water.

- Secure parasol with a 30 mA RCBO protective switch.
- According to law, the functioning of protective switches must be checked at least every six months.



Caution

Danger of short circuit.

Water in the plug connector can lead to a short circuit. Protect the connector against any water.

- Make sure that the plug connector remains above the ground when the parasol is erected, or seal the connector with silicon (or the like) to make it 100% waterproof.



Caution

Fire hazard.

Do not use a dimmer switch. Otherwise the parasol may catch fire. If the parasol is equipped with a timer switch or automatic switch off, a dimmer will interfere with the electrical system.

3. Wire colours (number dependent on consumers installed):

green-yellow	= protection
blue	= neutral
brown	= light (if used)
black, white	= heating (if used)
black	= heating (if used)

Gravel bed and stone slabs

1. Lay the gravel bed in the usual manner. Make sure that the connecting rubber lead has been run and protected properly.

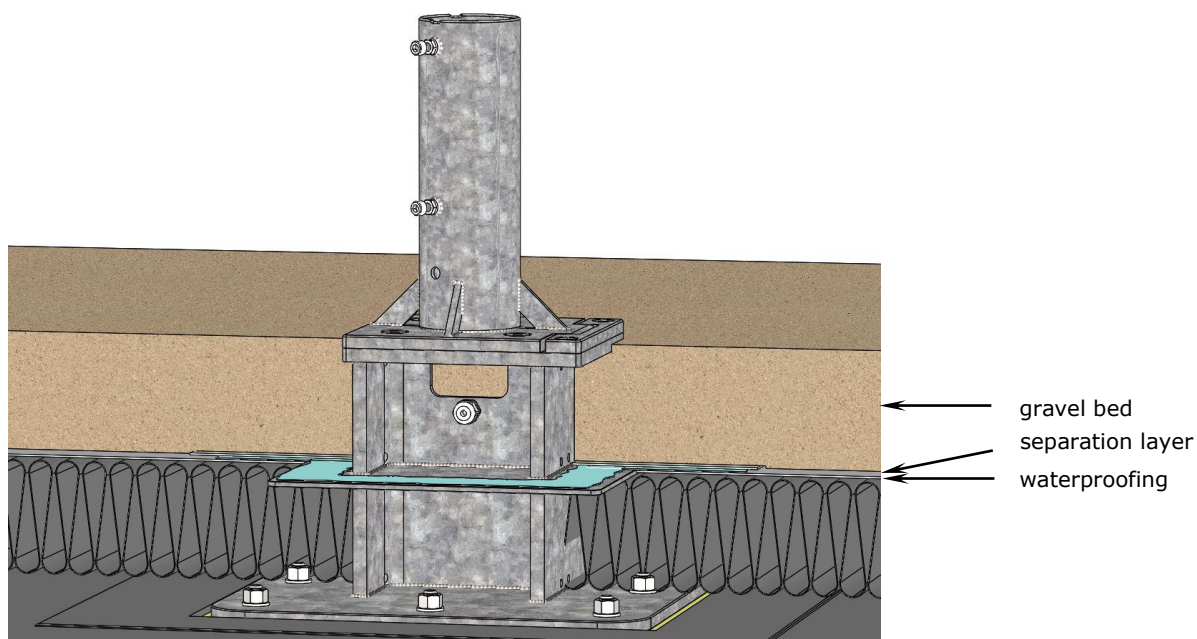

Attention

Avoid tripping hazard.

To ensure that the cover plate (needed as a protective cover in winter when the upper anchor foot has been removed) is flush, the bottom component must be set 4 mm below the terrace surface (cf. illustration). This difference of 4 mm corresponds to the space needed for the 4 mm-thick checker plate for winter protection.

- Match the height of the gravel bed to that of the stone slabs.

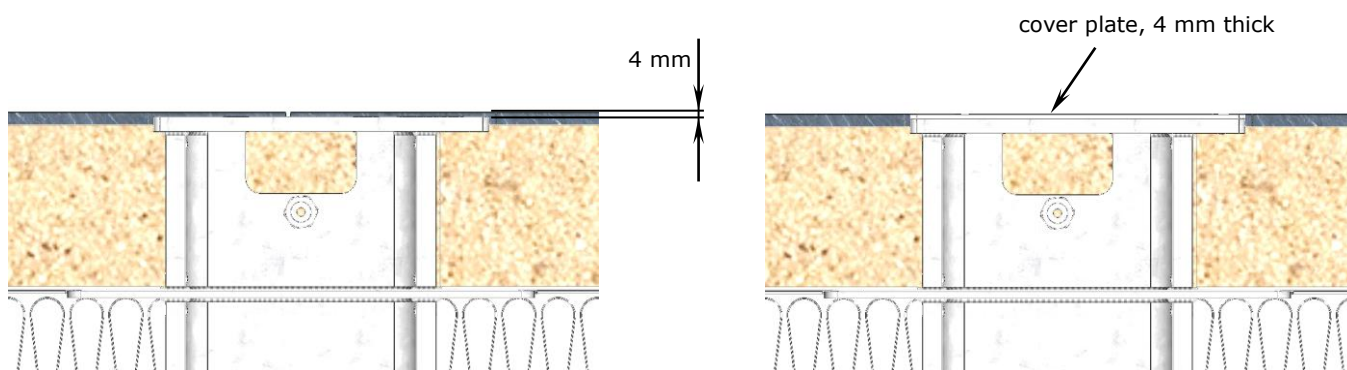

2. Lay the stone slabs and saw away the corners of those that are to fit round the AZ186. Make sure that the AZ186 sits flush.

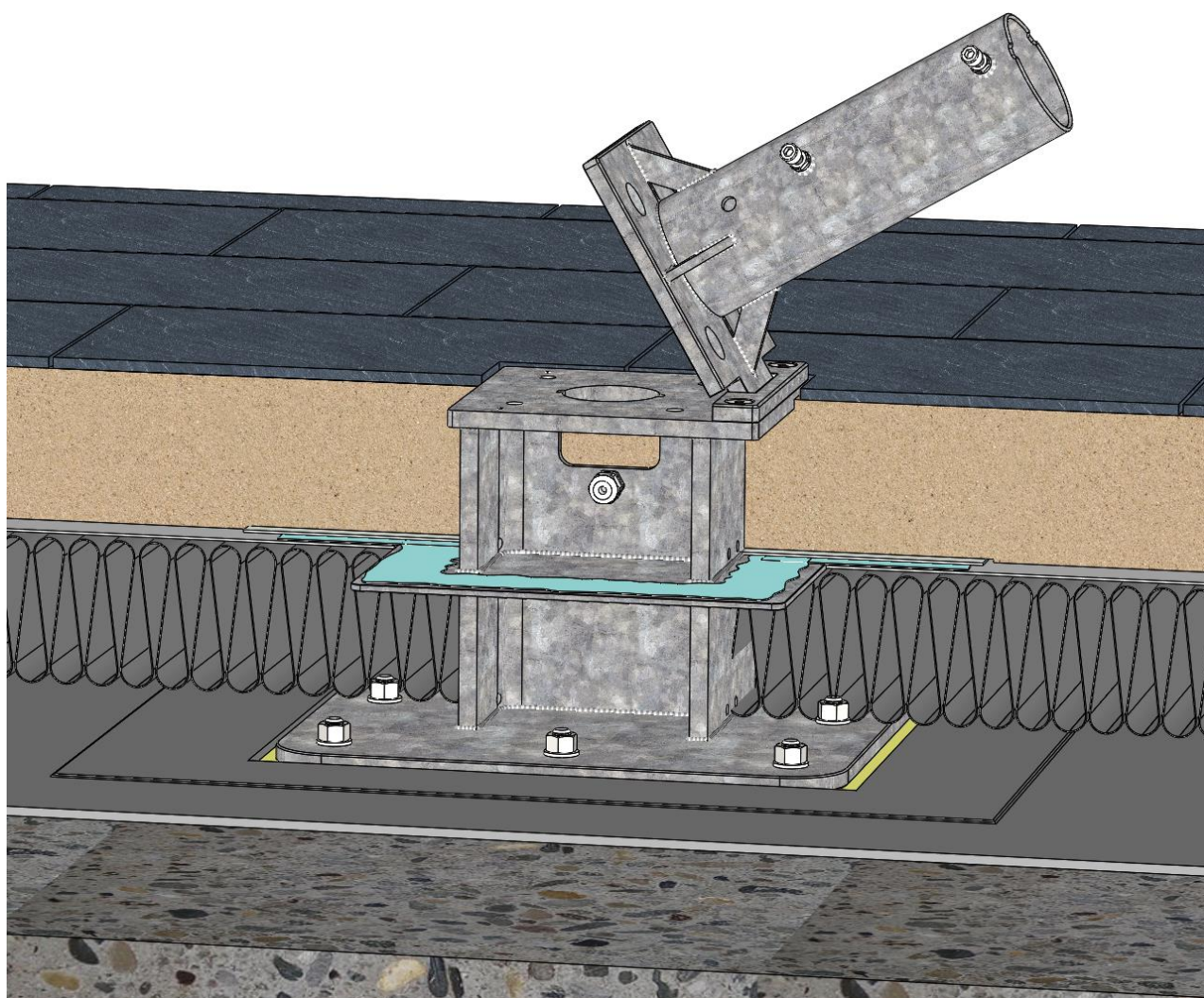
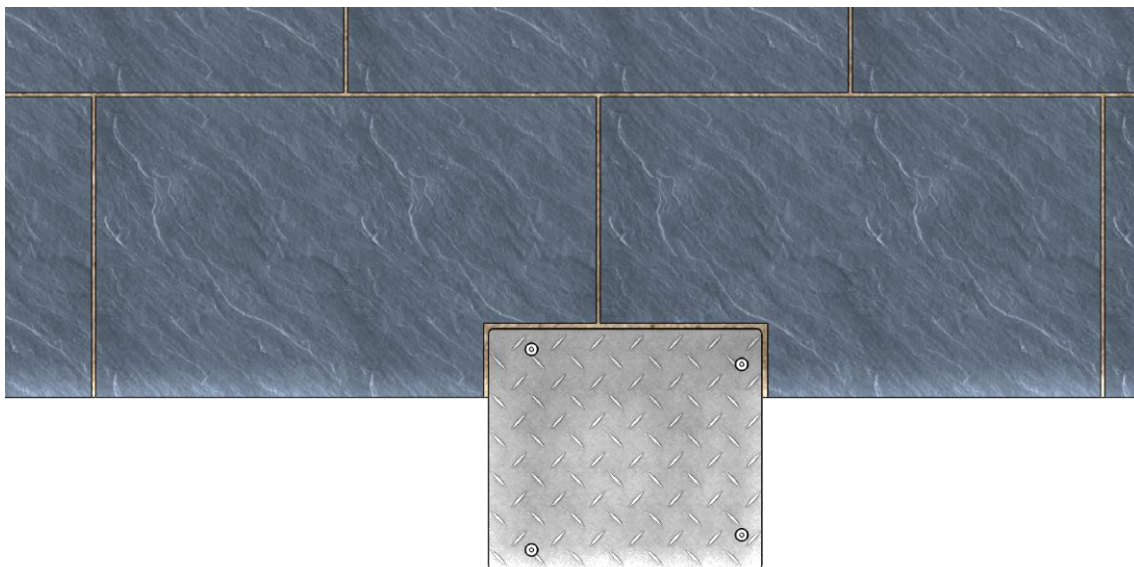

Storage / Dismounting

1. Fold down the upper foot with the closed parasol.
2. Disconnect the underground cable from the cable in the parasol pole.



Danger

Electric installation work should be carried out solely by a certified electrician. Disregarding this warning may result in serious personal injuries.

- First unplug the parasol (fuse box), then disconnect the ground cable from the parasol power cable.

3. Lift the parasol out of the foot.
4. Remove the upper foot completely by screwing it off.
5. Unscrew the set screws with a 3 mm hex key. These serve to protect the internal thread against dirty water and sand.
6. Screw the cover plate (for winter) onto the lower part (cf. illustration).



Caution

The thread can get damaged.

When the cover plate is not on the lower part, sand may get washed into the flanks of the thread. As sand is harder than steel, the thread may get damaged when the screw is turned.

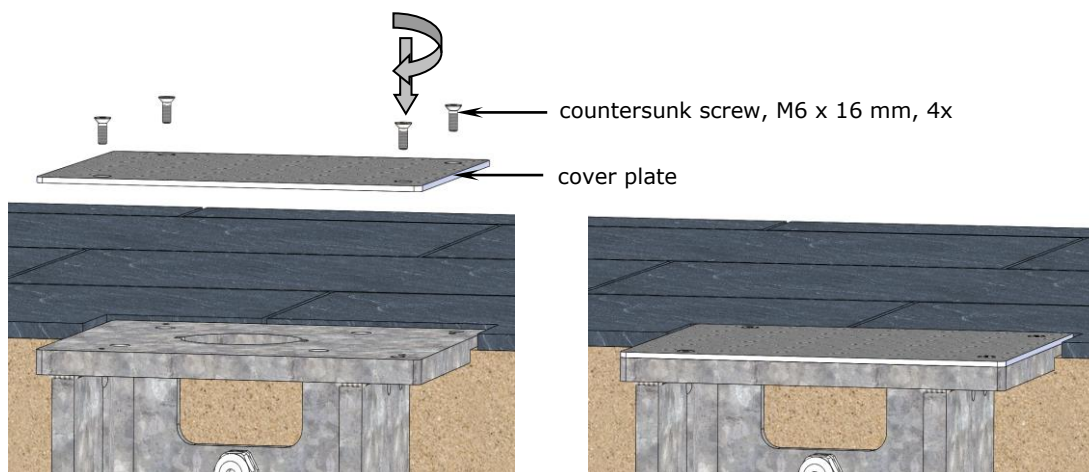

7. If you have two or more parasols, it is advisable to mark them and their accessories (e.g. with metal-stamped numerals or using a waterproof marker) as soon as they have been dismantled (e.g. for winter storage).



Tip

Marking saves a lot of time and helps to keep things in order.

If clearly marked, each parasol can easily be assigned to its proper location and re-erected parallel to the wall of the house or next to the others.

- For clear and easy later assignment use the same number to mark the centre pole, the upper anchor foot and the lower part. For example, for parasol No. 1, all three parts should carry number 1, all three parts of parasol No. 2 should be marked with a 2, etc.
-

8. Grease the screws regularly to prevent them from rusting.

Project management

All persons involved should discuss this installation option on site. If these instructions are provided to everyone during the planning period, arguments can be harmonised and therefore unnecessary costs for incorrect planning can be saved. In case this installation option is found not to be suitable, you may select another option from the MAY program. Customized options are available upon request depending on complexity.

Following parties may be involved:

1. House owner: Approval of project, assumption of costs, order placement, etc.
2. Leaseholder / gastronome: Is the positioning of the parasols suitable for the seating, assumption of costs, etc.
3. Architect: General legal planning, positioning, statics of the flat roof (dynamic and static load by weight and wind), control and supervision of the workmen, etc.
4. Workmen: Roofer clarifies and mounts the installation option, pay attention to waterproofing sealing, setting heavy-duty anchor bolts, etc.
5. Electrician: Defines electrical connection, clarifies cable and control, etc.

Dowel-anchored plate with placement hinge and glueboard, AZ186



This order sheet must be filled out completely and supplied to the MAY company before production.

In accordance with ETAG 005 guidelines for planning and execution of liquid-applied synthetic waterproofing for roofs, balconies and terraces.

art. no. AZ186: 2 pieces, screw-off upper part, fits for pole \varnothing 100 mm
 delivery content: inclusive pin and padlock, art. no. 200826

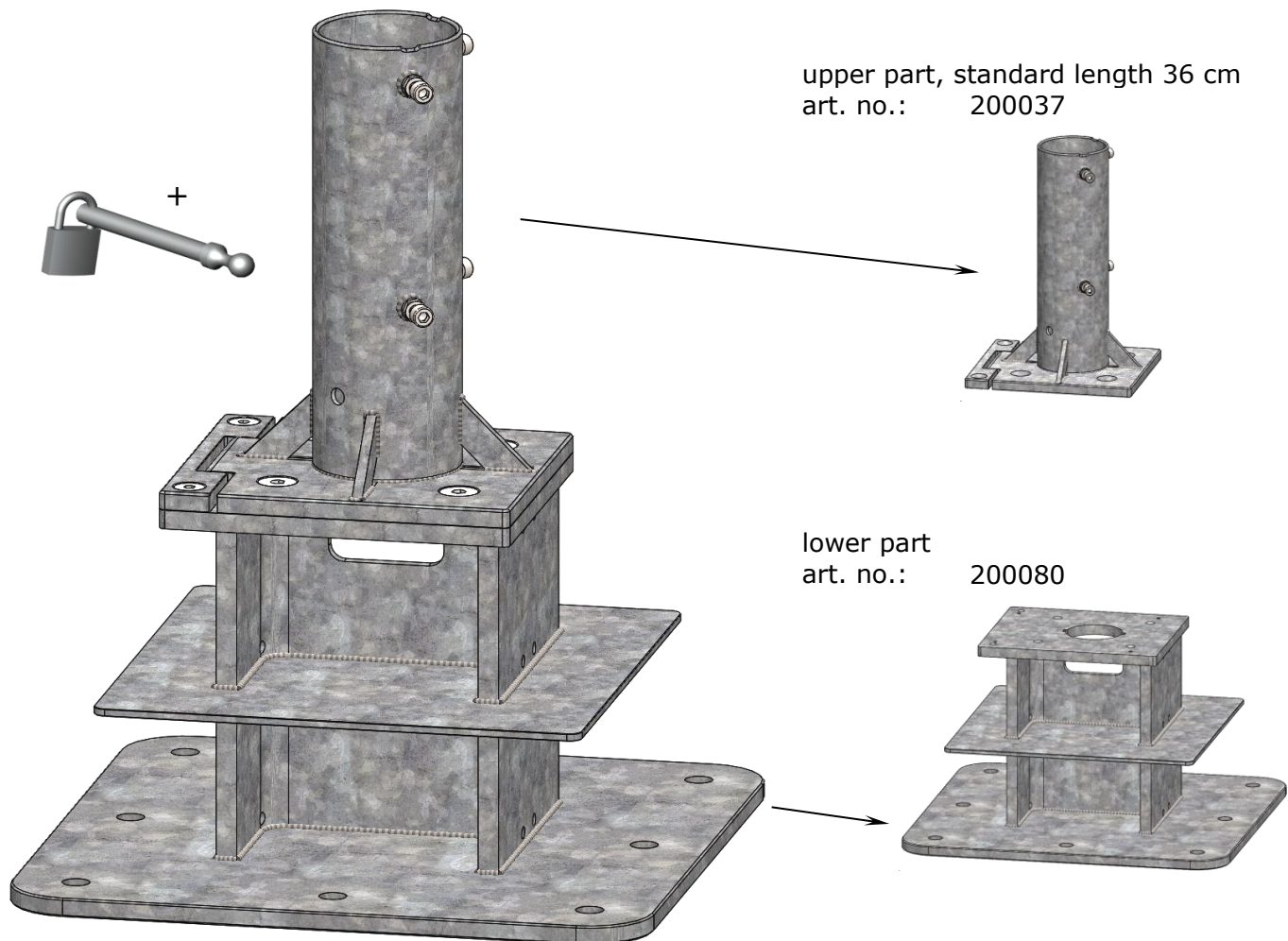

3-D views of AZ186

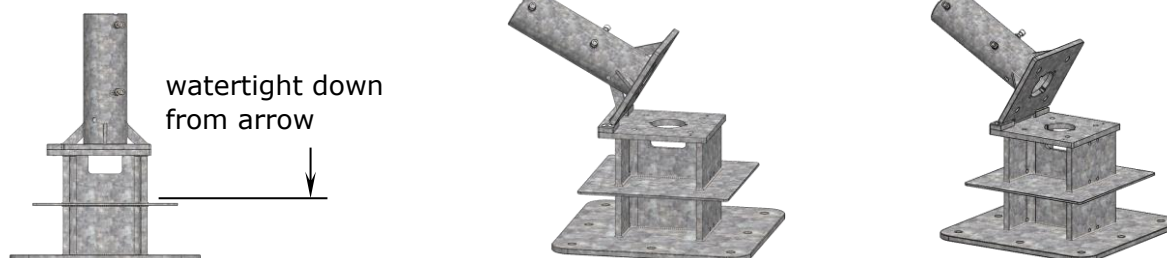

3-D view of lower part with top plate for winter protection.



Dowel-anchored plate with placement hinge and glueboard, AZ186



This order sheet must be filled out completely and supplied to the MAY company before production.

All bases are custom-made. When ordering, please state the total height required, including winter top plate.

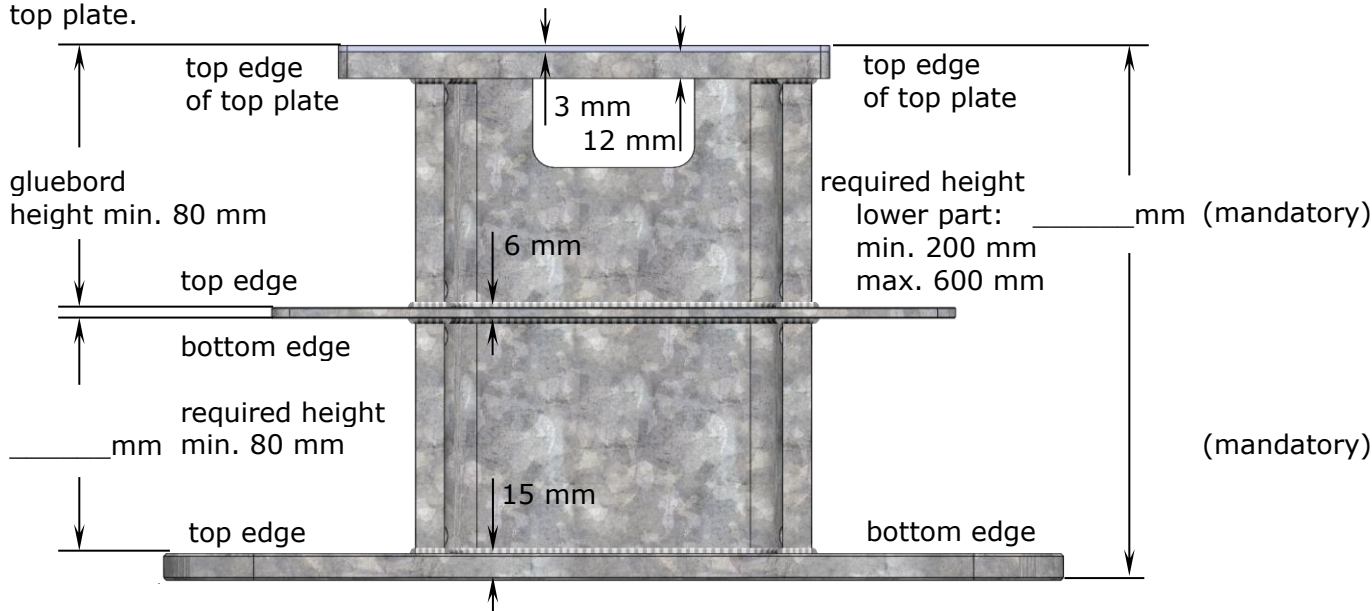

anchor plate:

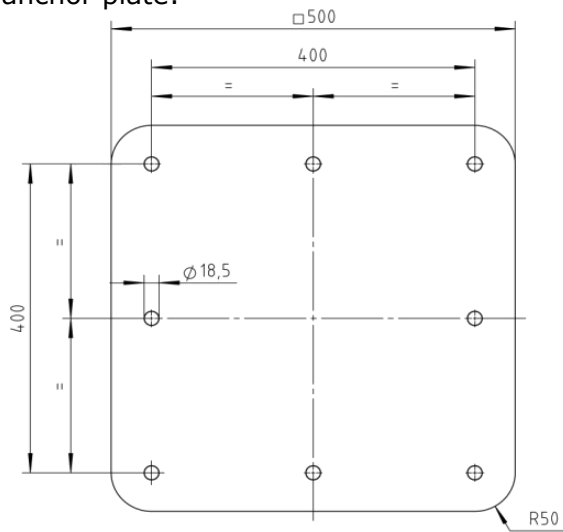

When drilling the heavy-duty anchor bolts into the designated site position, use the anchor plate as a drilling jig. You will need 8 heavy-duty anchor bolts. Available in stainless steel A4, art. no. 200900, 2 packages.

Cable gland for tension relief. Only necessary if power supply is planned.

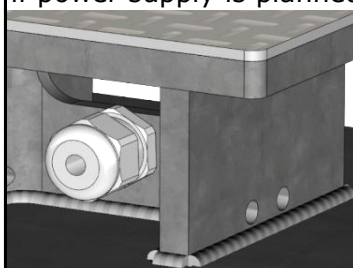

(mandatory)
required _____
not required _____

When ordering, please fill in the fields below:

Quantity: _____ (mandatory)

(Dealer-) Name and address: _____ (optional)

(Dealer-) Commission: _____ (optional)

(Dealer-) Order number: _____ (optional)

(Dealer-) Name of clerk in charge: _____ (optional)

Order placed: _____ (mandatory)

Name

Date

Only for MAY Gerätebau GmbH:

Order number: _____